

CARL heavy duty punches

120 – 122N – 124N

HD 410N – HD 530N

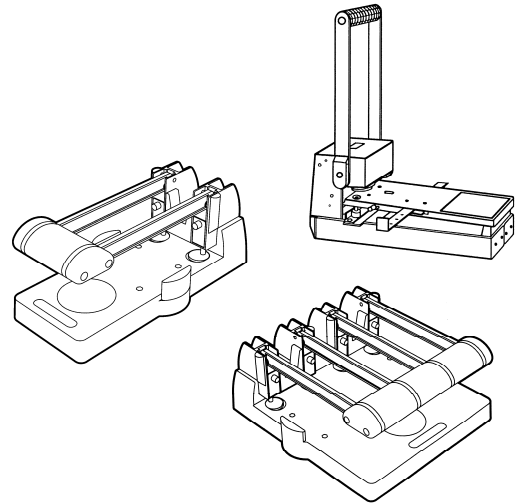

Materials:

- Made in metal and plastic materials
- Rubber feet for a perfect adhesion to the working surface

Technical / functional features: see table on next page

Spare parts: see table on next page

Descriptive notes: The materials and the mechanism employed in the manufacturing of CARL heavy duty punches assure high quality and resistance products, strong and elegant at the same time, thanks to the modern design.

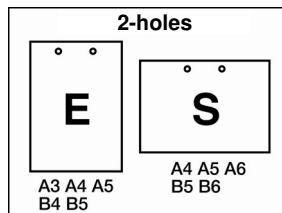
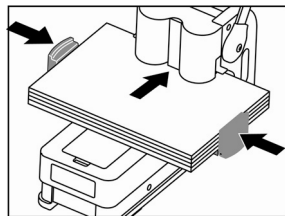

CARL 122N and HD-410N, equipped with the new "self-centring" guide, allow the automatic centring (2 holes) of the sheets from A4 up to B6 size.

CARL HD-530N, with the new self-centring guide with lowering edges, allows the automatic centring (2 and 4 holes) of the sheets from A3 up to A4 size.

CARL 120 have the sheet forking guide marked for the different punching positions, two or four holes, according to the different sheets sizes.

CARL 124 is ideal for a 4 holes punching along the long side of the A4 size sheets.

CARL models ref. HD-410N and HD-530N are provided with a new extraction system of the male-dies, for their easy replacement.

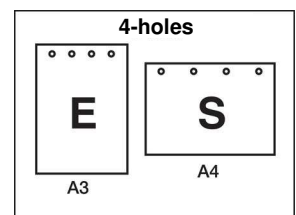
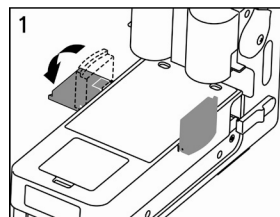

In addition: it is possible to obtain with little effort, also thanks to the ergonomic handle grips, an always precise punching without slavering, also for considerable paper thickness.

CARL heavy duty punches, manufactured by CARL MANUFACTURING CO., LTD. - TOKYO, are distributed in Italy exclusively by **BALMA, CAPODURI & C. s.p.a.**, which assures a good after-sale service too.

Product Safety (Regulation (EU) 2023/988)

Detailed instructions for use can be found inside each box.

Risks

- DO NOT allow children to use the punch, and ensure that it is kept out of their reach when not in use;
- DO NOT lower the handle if your hand or fingers are positioned under the punch heads;
- Do not touch the tip of the punch (risk of injury);
- DO NOT attempt to modify the functioning of the punch;
- FOR OPTIMAL USE always ensure that the punch is placed on a stable surface before operating it.

Precautions for Use

- Make sure staples and paper clips are removed from the area to be punched before use;
- Ensure that the paper is aligned with the self-centering guide. The maximum paper capacity should not exceed the limit indicated in the instructions;
- The punch should only be used for punching paper;
- Periodically check the wear condition of the punch heads and discs to ensure effective performance;
- Replace worn punch heads and discs with original CARL spare parts;
- Empty the paper chip container regularly;
- Do not use the punch in damp or dusty areas, in direct sunlight, or near sources of heat.

Technical / functional features:

REF.	CARL HD-410N	CARL 120	CARL 122N	CARL 124N	CARL HD-530N
Holes number:	2	2	2	4	2
Distance between the holes (mm)	80	80	80	80	80
Hole diameter (mm):	6	6	6	6	6
Punching capacity (paper 80 g/sqm):	100 sheets	145 sheets	150 sheets		275 sheets
Punching depth :	Fixed 9 mm	Adjustable From 6 to 14 mm	Fixed 9 mm		Fixed 9 mm
Sheets forking guide	Self-centring	Supplied	Self-centring	Fixed	Self-centring
Colour:	GREY/BLACK	GREY/BLACK	GREY/BLACK	GREY/BLACK	GREY/BLACK
Weight (net/gross) g:	2800 / 3000	4100 / 4430	2700 / 3000	5000 / 6000	6000 / 6600
Dimensions (mm)⁽¹⁾:	241 x 164 x 140 h	330 x 140 x 375 h	338 x 170 x 175 h	338 x 315 x 175 h	234 x 445 x 225 h

(1) the height (h) of the punches indicated above is meant with the handle completely lowered

Spare parts:

REF.	Description	Pieces per packing
CARL P-86MD	Spare male-dies for CARL punch 86	2
CARL P-90MD	Spare male-dies for CARL punch 90	1
CARL P-120MD	Spare male-dies for CARL punch 120	1
CARL P-122/124MD	Spare male-dies for CARL punches 122 - 122N - 124N	1
CARL P-160MD	Spare male-dies for CARL punch 160	1
CARL P-HD410MD	Spare male-dies for CARL punches HD 410 - HD 410N	1
CARL P-HD430MD	Spare male-dies for CARL punches HD 430 - HD 430N	1
CARL P-HD530MD	Spare male-dies for CARL punch HD 530N	1
CARL 852	Spare disks for CARL punches 122 - 122N - 124 - 124N - HD 410 - HD 410N - HD 430 - HD 430N	10
CARL P-B02	Spare disks for CARL punch HD 530N	10